

Code : 021102

B.Tech 1st Semester Exam., 2017

ENGINEERING GRAPHICS

Time : 3 hours

Full Marks : 70

Instructions :

- (i) The marks are indicated in the right-hand margin.
- (ii) There are **NINE** questions in this paper.
- (iii) Attempt **FIVE** questions in all.
- (iv) Question No. **1** is compulsory.

1. Choose the correct option (any seven) : $2 \times 7 = 14$

(a) The size of A1 drawing sheet recommended by the Bureau of Indian Standard is

- (i) 841 mm \times 1189 mm
- (ii) 594 mm \times 841 mm
- (iii) 420 mm \times 594 mm
- (iv) 297 mm \times 420 mm

(b) Continuous thin line is not used for

- (i) dimension line
- (ii) extension line
- (iii) visible outline
- (iv) hatching

(c) Which one is the enlarging scale?

- (i) 1:1
- (ii) 1:2
- (iii) 5:1
- (iv) 1:10

(d) In the first angle projection method, what are relative positions of the object, plane of projection and observer?

- (i) Object is placed in between the plane and observer
- (ii) Plane is placed in between the observer and object
- (iii) Observer is in between the object and the plane
- (iv) May be placed in any order

- (e) Front view is projected on the
- (i) profile plane
 - (ii) Horizontal plane
 - (iii) vertical plane
 - (iv) None of the above
- (f) If a point is in second quadrant
- (i) front view will be above reference line
 - (ii) front view will be below reference line
 - (iii) top view will be below reference line
 - (iv) None of the above
- (g) The FV and TV of a line represent true lengths, if the line is
- (i) parallel to HP and perpendicular to VP
 - (ii) parallel to VP and perpendicular to HP
 - (iii) parallel to both HP and VP
 - (iv) parallel to VP and inclined to HP

- (h) In dimensioning of cylindrical part the dimension indicating a diameter should always be preceded by the symbol
- (i) θ
 - (ii) Ω
 - (iii) ψ
 - (iv) ϕ
- (i) The eccentricity (e) for parabola is
- (i) > 1
 - (ii) $= 1$
 - (iii) < 1
 - (iv) $= 2$
- (j) TV view of a square plane parallel to HP and perpendicular to VP is a
- (i) straight line
 - (ii) point
 - (iii) rectangle
 - (iv) square

(5)

2. A line AB , inclined at 40° to the VP, has its ends 50 mm and 20 mm above the HP. The length of its front view is 65 mm and its VT is 10 mm above the HP. Determine the true length of AB , its inclination with HP and its HT. 14
3. Draw the projections of a regular hexagon of 25 mm side, having one of its sides in the HP and inclined at 60° to the VP, and its surface making an angle of 45° with the HP. 14
4. Draw the projections of a pentagonal prism, base 25 mm side and axis 50 mm long, resting on one of its rectangular faces on the HP, with the axis inclined at 45° to the VP. 14
5. A cylinder, 65 mm diameter and 90 mm long, has its axis parallel to the HP and inclined at 30° to the VP. It is cut by a vertical section plane in such a way that the true shape of the section is an ellipse having the major axis 75 mm long. Draw its sectional front view and true shape of the section. 14

(6)

6. An air-conditioner duct of a square cross-section $70\text{ mm} \times 70\text{ mm}$ connects a circular pipe of 40 mm diameter through the transition piece. Draw the projections and develop the lateral surface of the transition piece. 14
7. A cone, 90 mm diameter of base, axis 110 mm long, stands on the ground and is completely penetrated by a cylinder, 50 mm diameter and 110 mm long. The axis of the cylinder is horizontal, parallel to the VP and passes through the axis of the cone, 75 mm from the apex. Draw the projections of both curves of intersection. 14
8. A hexagonal prism having the side of the base 26 mm and the height of 60 mm is resting on one of the corners of the base and its axis is inclined to 30° to the HP. Draw its projections and also prepare the isometric view of the prism in the above stated condition. 14

(7)

9. Pictorial view of an object is given below :

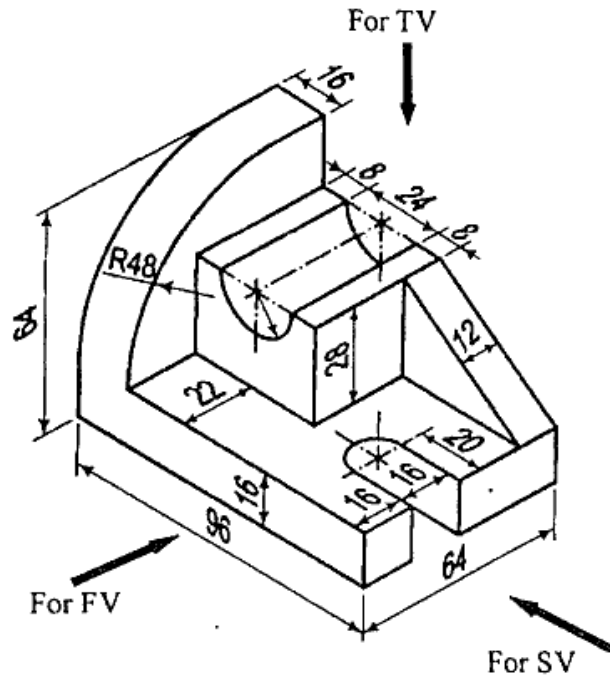

Draw three views of this object by first angle projection method.

14
