

**B.Tech 6th Semester Exam., 2019**

**DESIGN OF MACHINE ELEMENTS**

Time : 3 hours

Full Marks : 70

Instructions :

- (i) All questions carry equal marks.
- (ii) There are **NINE** questions in this paper.
- (iii) Attempt **FIVE** questions in all.
- (iv) Question No. 1 is compulsory.
- (v) Students are allowed to use design data book.

1. Choose the correct answer of the following (any seven) :

- (a) Which of the following parameters can be obtained by tension test of a standard specimen?
  - (i) Proportional limit
  - (ii) Yield strength
  - (iii) Percentage reduction in area
  - (iv) All of the above

(b) Which of the following is the definition of compliance?

- (i) Inverse of rigidity
- (ii) Inverse of stiffness
- (iii) Proportional to elastic limit
- (iv) None of the above

(c) Yield strength is defined as the maximum stress at which a marked increase in elongation occurs without increase in

- (i) load
- (ii) strength
- (iii) toughness
- (iv) hardness

(d) Relative density of aluminium is roughly \_\_\_\_\_ of steel.

- (i) one-third
- (ii) one-fifth
- (iii) one-tenth
- (iv) equal

- (e) Which of the following are true for aluminium?
- (i) Low specific gravity
  - (ii) Corrosion resistance
  - (iii) High thermal conductivity
  - (iv) All of the above
- (f) In alloy 4450, 4 represents
- (i) silicon
  - (ii) aluminium
  - (iii) manganese
  - (iv) zinc
- (g) Ductile cast iron is
- (i) nodular cast iron
  - (ii) spheroidal graphite cast iron
  - (iii) carbon is present in the form of spherical nodules
  - (iv) All of the above
- (h) Grey cast iron is formed when
- (i) carbon content in the alloy exceeds the amount that can be dissolved
  - (ii) carbon content in the alloy is less than the amount that can be dissolved
  - (iii) carbon content in the alloy is equal to the amount that can be dissolved in the alloy
  - (iv) None of the above

- (i) Which of the following are true?
- (i) Brass is costlier than copper
  - (ii) Brass has excellent corrosion resistance
  - (iii) Brass has good machinability
  - (iv) Brass has poor thermal conductivity
- (j) Proof strength is defined as the stress which will produce a permanent extension of how much percentage in the gauge length of the standard test specimen
- (i) 0.1
  - (ii) 0.2
  - (iii) 0.3
  - (iv) 0.4

2. Two rods, made of plain carbon steel 40C8 ( $S_{yt} = 380 \text{ N/mm}^2$ ), are to be connected by means of a cotter joint. The diameter of each rod is 50 mm and the cotter is made from a steel plate of 15 mm thickness. Calculate the dimensions of the socket end making following assumptions :

- (a) The yield strength in compression is twice of the tensile yield strength
- (b) The yield strength in shear is 50% of the tensile yield strength

The factor of safety is 6.

( 5 )

3. A component machined from a plate made of steel 45C8 ( $S_{ut} = 630 \text{ N/mm}^2$ ) is shown in Fig. 1. It is subjected to a completely reversed axial force of 50 kN. The expected reliability is 90% and the factor of safety is 2. The size factor is 0.85. Determine the plate thickness  $t$  for infinite life, if the notch sensitivity factor is 0.8 :

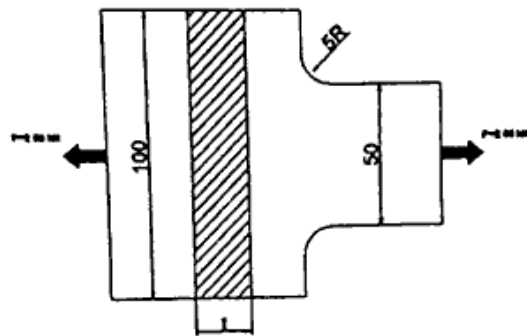

Fig. 1

4. A welded connection, as shown in Fig. 2 is subjected to an eccentric force of 7.5 kN. Determine the size of welds if the permissible shear stress for the weld is  $100 \text{ N/mm}^2$ . Assume static conditions :

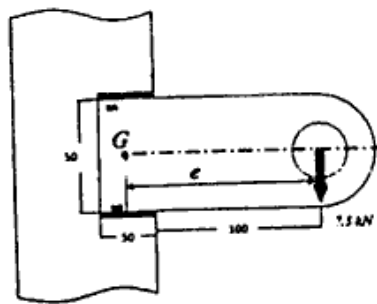

Fig. 2

( 6 )

5. A cylindrical pressure vessel with 1 m inner diameter is subjected to internal steam pressure of 1.5 MPa. The permissible stresses for the cylinder plate and the rivets in tension, shear, and compression are 80, 60 and  $120 \text{ N/mm}^2$  respectively. The efficiency of longitudinal joint can be taken as 80% for the purpose of calculating the plate thickness. The corrosion allowance is 2 mm. The efficiency of circumferential lap joint should be at least 62%. Design the circumferential lap joint and calculate—
- thickness of the plate;
  - diameter of the rivets;
  - number of rivets;
  - pitch of rivets;
  - number of rows of rivets;
  - overlap of the plates.
6. It is required to design a square key for fixing a gear on a shaft of 25 mm diameter. The shaft is transmitting 15 kW power at 720 r.p.m. to the gear. The key is made of steel 50C4 ( $S_{yt} = 460 \text{ N/mm}^2$ ) and the factor of safety is 3. For key material, the yield strength in compression can be assumed to be equal to the yield strength in tension. Determine the dimension of the key.

( 7 )

7. Design a muff coupling to connect two steel shafts transmitting 25 kW power at 360 r.p.m. The shafts and key are made of plain carbon steel 30C8 ( $S_{yt} = S_{yc} = 400 \text{ N/mm}^2$ ). The sleeve is made of grey cast iron FG200 ( $S_{ut} = 200 \text{ N/mm}^2$ ). The factor of safety for the shaft and key is 4. For sleeve, the factor of safety is 6 based on ultimate strength.

8. A hard-drawn steel wire extension spring has a wire diameter of 0.9 mm, an outside coil diameter of 6.3 mm, hook radii of  $r_1 = 2.7 \text{ mm}$  and  $r_2 = 2.3 \text{ mm}$ , and an initial tension of 5 N. The number of body turns is 12.17. From the given information—

- (a) determine the physical parameters of the spring;
- (b) check the initial preload stress conditions;
- (c) find the factors of safety under a static 23 N load.

9. The following data is given for an open-type V-belt drive :

Diameter of driving pulley = 150 mm

Diameter of driven pulley = 300 mm

Centre distance = 1 m

Groove angle =  $40^\circ$

( 8 )

Mass of belt = 0.25 kg/m

Maximum permissible tension = 750 N

Coefficient of friction = 0.2

Plot a graph of maximum tension and power transmitted against the belt velocity. Calculate the maximum power transmitted by the belt and the corresponding belt velocity. Neglect power losses.

\*\*\*