

## B.Tech 6th Semester Exam., 2022

( New Course )

## DESIGN OF MACHINE ELEMENTS

Time : 3 hours

Full Marks : 70

Instructions :

- (i) The marks are indicated in the right-hand margin.
- (ii) There are **NINE** questions in this paper.
- (iii) Attempt **FIVE** questions in all.
- (iv) Question No. 1 is compulsory.

1. Choose the correct answer (any seven) :

2×7=14

- (a) 18/8 steel contains
  - (i) 18 percent nickel and 8 percent chromium
  - (ii) 18 percent chromium and 8 percent nickel
  - (iii) 18 percent nickel and 8 percent vanadium
  - (iv) 18 percent vanadium and 8 percent nickel

- (b) The parts of circular cross-section which are symmetrical about the axis of rotation are made by
  - (i) hot forging
  - (ii) hot extrusion
  - (iii) hot spinning
  - (iv) hot drawing
- (c) The ratio of linear stress to linear strain is called
  - (i) modulus of elasticity
  - (ii) modulus of rigidity
  - (iii) bulk modulus
  - (iv) Poisson's ratio
- (d) Two shafts will have equal strength, if
  - (i) diameter of both the shafts is same
  - (ii) angle of twist of both the shafts is same
  - (iii) material of both the shafts is same
  - (iv) twisting moment of both the shafts is same
- (e) A line joining the centres of rivets and parallel to the edge of the plate is known as
  - (i) back pitch
  - (ii) marginal pitch
  - (iii) gauge line
  - (iv) pitch line

- (f) In transverse fillet welded joint, the size of weld is equal to
- 0.5 × throat of weld
  - throat of weld
  - 1.414 × throat of weld
  - 2 × throat of weld
- (g) A spring used to absorb shocks and vibrations is
- leaf spring
  - open-coiled helical spring
  - conical spring
  - torsion spring
- (h) The material used for lining of friction surfaces of a clutch should have \_\_\_ coefficient of friction.
- low
  - high
- (i) A brake commonly used in motorcars is
- shoe brake
  - band brake
  - band and block brake
  - internal expanding brake
- (j) The number of starts on the worm for a velocity ratio of 40 should be
- single
  - double
  - triple
  - quadruple

2. (a) State the advantages and disadvantages of hot working of metals. Discuss any two hot working processes. 6
- (b) A steel rod of 20 mm diameter passes centrally through a copper tube of external diameter 40 mm and internal diameter 20 mm. The tube is closed at each end with the help of rigid washers (of negligible thickness) which are screwed by the nuts. The nuts are tightened until the compressive load on the copper tube is 50 kN. Determine the stresses in the rod and the tube, when the temperature of whole assembly falls by 50 °C. Take  $E_s = 200$  GPa;  $E_c = 100$  GPa;  $\alpha_s = 12 \times 10^{-6} / ^\circ\text{C}$  and  $\alpha_c = 18 \times 10^{-6} / ^\circ\text{C}$ . 8
3. (a) How is the shaft designed when it is subjected to twisting moment only? 6
- (b) A mild steel shaft transmits 20 kW at 200 r.p.m. It carries a central load of 900 N and is simply supported between the bearings 2.5 meters apart. Determine the size of the shaft, if the allowable shear stress is 42 MPa and the maximum tensile or compressive stress is not to exceed 56 MPa. What size of the shaft will be required, if it is subjected to gradually applied loads? 8

4. (a) Classify the rivet heads according to Indian Standard specifications. 6
- (b) Find the efficiency of the following riveted joints : 8
- (i) Single riveted lap joint of 6 mm plates with 20 mm diameter rivets having a pitch of 50 mm
- (ii) Double riveted lap joint of 6 mm plates with 20 mm diameter rivets having a pitch of 65 mm

Assume permissible tensile stress in plate = 120 MPa, permissible shearing stress in rivets = 90 MPa, permissible crushing stress in rivets = 180 MPa.

5. (a) A bracket shown below, carries a load of 10 kN. Find the size of the weld if the allowable shear stress is not to exceed 80 MPa : 7

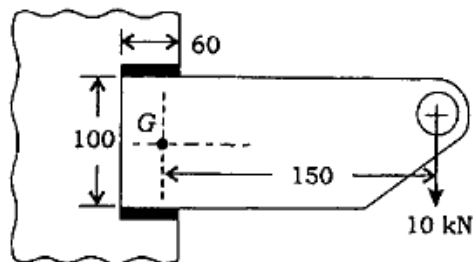

All dimensions are in mm

- (b) A  $125 \times 95 \times 10$  mm angle is joined to a frame by two parallel fillet welds along the edges of 150 mm leg. The angle is subjected to a tensile load of 180 kN. Find the lengths of weld if the permissible static load per mm weld length is 430 N. 7
6. (a) With the help of neat sketches, differentiate between single and multi-plate clutches. 6
- (b) A multiple disc clutch, steel on bronze, is to transmit 4.5 kW at 750 r.p.m. The inner radius of the contact is 40 mm and outer radius of the contact is 70 mm. The clutch operates in oil with an expected coefficient of 0.1. The average allowable pressure is  $0.35 \text{ N/mm}^2$ . Find— 8
- (i) the total number of steel and bronze discs;
- (ii) the actual axial force required;
- (iii) the actual average pressure;
- (iv) the actual maximum pressure.
7. (a) Discuss the different types of brakes giving at least one practical application for each. 6

( 7 )

(b) A double-shoe brake, as shown in the figure below, is capable of absorbing a torque of 1400 N-m. The diameter of the brake drum is 350 mm and the angle of contact for each shoe is  $100^\circ$ . If the coefficient of friction between the brake drum and lining is 0.4; find—

- (i) the spring force necessary to set the brake;
- (ii) the width of the brake shoes, if the bearing pressure on the lining material is not to exceed  $0.3 \text{ N/mm}^2$  :

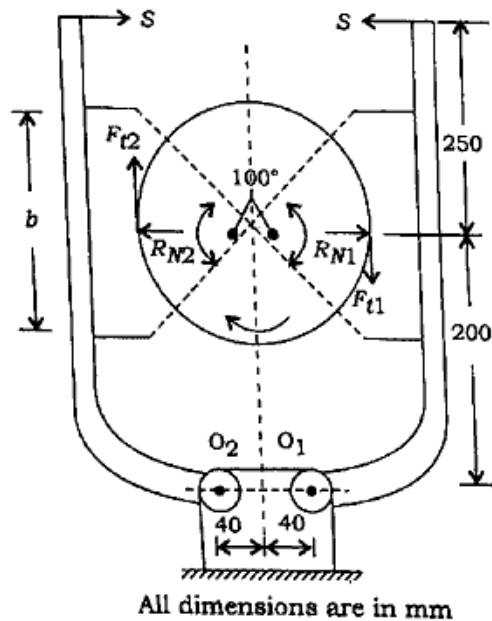

8

( 8 )

8. A 15 kW and 1200 r.p.m. motor drives a compressor at 300 r.p.m. through a pair of spur gears having  $20^\circ$  stub teeth. The centre-to-centre distance between the shafts is 400 mm. The motor pinion is made of forged steel having an allowable static stress as 210 MPa while the gear is made of cast steel having an allowable static stress as 140 MPa. Assuming that the drive operates 8 to 10 hours per day under light shock conditions, find from the standpoint of strength, (a) Module; (b) Face width and (c) Number of teeth and pitch circle diameter of each gear. Check the gears thus designed from the consideration of wear. The surface endurance limit may be taken as 700 MPa. 14

9. (a) What are springs? Differentiate between helical springs, conical springs and laminated springs with neat sketches. 6
- (b) Design a close-coiled helical compression spring for a service load ranging from 2250 N to 2750 N. The axial deflection of the spring for the load range is 6 mm. Assume a spring index of 5. The permissible shear stress intensity is 420 MPa and modulus of rigidity  $G = 84 \text{ kN/mm}^2$ . Neglect the effect of stress concentration. Draw a fully dimensioned sketch of the spring, showing details of the finish of the end coils. 8

\*\*\*